

BIG-FOOT® POLYMER SLURRY  
**MIXING GUIDE**

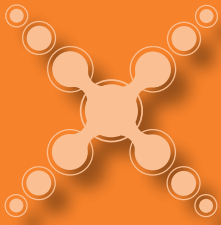

SLURRY  
 DRILLED SHAFTS



Certified to  
 NSF/ANSI 60



**BIG-FOOT®**  
 POLYMER SLURRY

Clay and Shale Stabilization  
 Mixes Smoothly into Flowing Water

Improves Borehole Stability  
 Non-Gelling / Self-Cleaning

SOIL FORMATION	BIG-FOOT® POLYMER MIX RATIO*		WATER FURNISHING RATIO**	
	100%	50/50 mix	100%	50/50
Clay & Sand	2.0-1.2	0.5-0.5	0.5-0.5	40-50
Clay & Shale (Stabilization Ratio)	1.0-1.20	0.5-0.5	0.5-0.50	70-110
Shale (Stabilization)	1.0-1.2	0.5-0.5	0.5-0.5	100-100
Shale/Clay	1.0-0.5	0.5-0.5	0.5-0.5	100-100

TYPICAL PROPERTIES	
Appearance	White granular solid
Specific Gravity	2.2 to 2.5
Particle Size	1,000-200 microns / 100 mesh
Water Solubility	100%
Odor	None

DISCLAIMER: BIG-FOOT should be mixed at a maximum rate of 6 to 8.5 (1,000 gal of fresh water production with 100-2000 lbs). Each major product line should be done in a properly designed mixing tank.  
 \* In applications where boreholes, cut-off or deviator connections slurry is to used as make-up water, BIG-FOOT dosage should be increased.



MATRIX CONSTRUCTION PRODUCTS  
 Net Contents: 35 lb (15.80 kg)  
 MATRIX Construction Products, LLC  
 677.506.5107 • matrix.com





Drilling Fluids • Additives • Chemicals • Testing Equipment • Mixers

906-542-4387 orders@matrixcp.com

**BIG-FOOT is real! A new dimension in construction products.**



The Benefits of BIG-FOOT® Polymer Slurry .....	3
BIG-FOOT Polymer Slurry and Additives .....	4
Slurry Batch Plant Elevations .....	5
Mixer on Ground & Tanks .....	6
Tank Set-up On Ground .....	7
BIG-FOOT Polymer Slurry Mixing .....	8
IN-THE-HOLE Mixing Instructions .....	9
Monitoring The Drilling Slurry .....	11
Slurry Loss .....	12
Pouring Concrete .....	12
Ingredients of BIG-FOOT Polymer Slurry .....	13
Recycling.....	13
Breakdown and Disposal.....	14

# BIG-FOOT® Polymer Slurry

With enhanced side wall stabilization and improved fluid loss control, BIG-FOOT is manufactured to improve quality control of the slurry and offers improved performance inside the excavation. Easy to mix and longer lasting, BIG-FOOT is the most advanced and highest performing polymer slurry product available.



Certified to  
NSF/ANSI 60

This guide provides detailed instructions on the correct use of BIG-FOOT® Polymer Slurry and supplemental additives. Explained in this document is the standard way to handle and mix BIG-FOOT Polymer Slurry. BIG-FOOT is a water-soluble polymer packaged as a granular material that works with a complete system process. Designed as a primary fluid, BIG-FOOT offers ease of use and reliable field success when used in the construction of drilled shafts and bored piles.

MATRIX CONSTRUCTION PRODUCTS® (MATRIX) has over 30 years of experience in drilling fluids and proprietary approaches to drilling issues that offer significant value and operational insight to our clients. BIG-FOOT® Polymer Slurry technology is the result of 15+ years of research and development by industry experts.

## Benefits of BIG-FOOT® Polymer Slurry

Time and money are important resources for all of our customers. Using BIG-FOOT high molecular weight polymer slurry offers improved excavation quality, due to its ability to self clean and maintain hole stability.

### ADDITIONAL BENEFITS INCLUDE:

- High performing concentration requires less slurry
- Increased productivity with BIG-FOOT's consistent performance
- Mixes into solution quickly with MATRIX mixer
- Portable, resulting in less energy and lower transportation costs
- Low cost to dispose of used slurry upon project completion



## BIG-FOOT® Polymer Slurry and Additives

MATRIX Construction Products offers a complete range of products that complement BIG-FOOT polymer and reinforce the functions of the drilling slurry when geologic conditions such as free-flowing sands, gravels and cobbles demand. BIG-FOOT controls fluid loss, resulting in reduced quantities of polymer consumed.

Additives should be used according to the suggested specifications in the products table below. The mixing instructions outline the effects that pH, chlorine levels, contaminant levels, mix water behavior and other restrictions have on the BIG-Foot slurry performance. MATRIX Construction Products offers product data sheets for their complete product line. MATRIX products are to be used with approval of the engineer and in accordance with MATRIX recommendations.

PRODUCT	SUGGESTED MIXING AMOUNT	TYPE OF PRODUCT	PURPOSE
<b>M-BOOSTER®</b> Dry pH Adjuster	6-8 lb/1,000 gal mix water	Dry mix water pH adjuster	Optimizes BIG-FOOT polymer performance and yield
<b>FORTIFY®</b> Slurry Loss Additive	4-6 lb/1,000 gal mix water	Dry cellulosic polymer	Filtration control/slurry sealant
<b>BIG-FOOT®</b> Polymer Slurry	8.0-9.0 lb/1,000 gal mix water	PHPA dry polymer (high molecular weight)	Primary polymer slurry to fortify the excavation
<b>MO'S-MUD®</b> Strong Viscosity Booster	5 gal/6,000 gal used slurry	1 gal/1,000 gal pre-mixed slurry to boost viscosity	Stabilizes loose granular soil/ instant viscosity when added directly at the hole
<b>GEO-NET®</b> Slurry Loss Circulation Material	30 lb/3,000 gal pre mixed slurry	Soluble fibrous lost-circulation material	Cuts slurry seepage into open sands & gravels
<b>GRID-LOCK®</b> Swellable Specialty Sealant	Add 10-20 lb (1-2 pails) straight into excavation slurry	Water-swellable solid crystalline polymer	Controls loss of slurry into sidewalls of excavation
<b>MESH-SET®</b> Granular Sealing Material	Add into hole to stop slurry loss	8-12 mesh granular sealant	Sealing and plugging agent
<b>BLOCK-AID®</b> Plugging Mineral Chips	Add directly into slurry filled hole to control slurry loss	3/8"-3/4" sized graded sealing and plugging agent	Treats and controls advanced slurry loss conditions
<b>RAPID-DROP®</b> Fast Acting Dry Flocculant	40 lb/3,500 gal used slurry	Responsive separating catalyst	Added into slurry acts rapidly to drop fines held in suspension
<b>FAST-FLOC®</b> Rapid Acting Liquid Flocculant	5 gal/6,000 gal used slurry	Liquid nonionic flocculant	Extremely effective at cleaning slurry prior to pouring concrete
<b>CHLOR-AWAY®</b> Dry Chlorine Neutralizer	2 lb/1,000 gal municipal water	Chlorine removal	Prevents early decrease in viscosity of slurry
<b>NEUTRALIZER®</b> BIG-FOOT Polymer Slurry Breaker	15 lb/6,000 gal used slurry	Dry reducing compound	Slurry breaker for disposal





### BIG-FOOT® Polymer Slurry Batch Plant SIDE ELEVATION

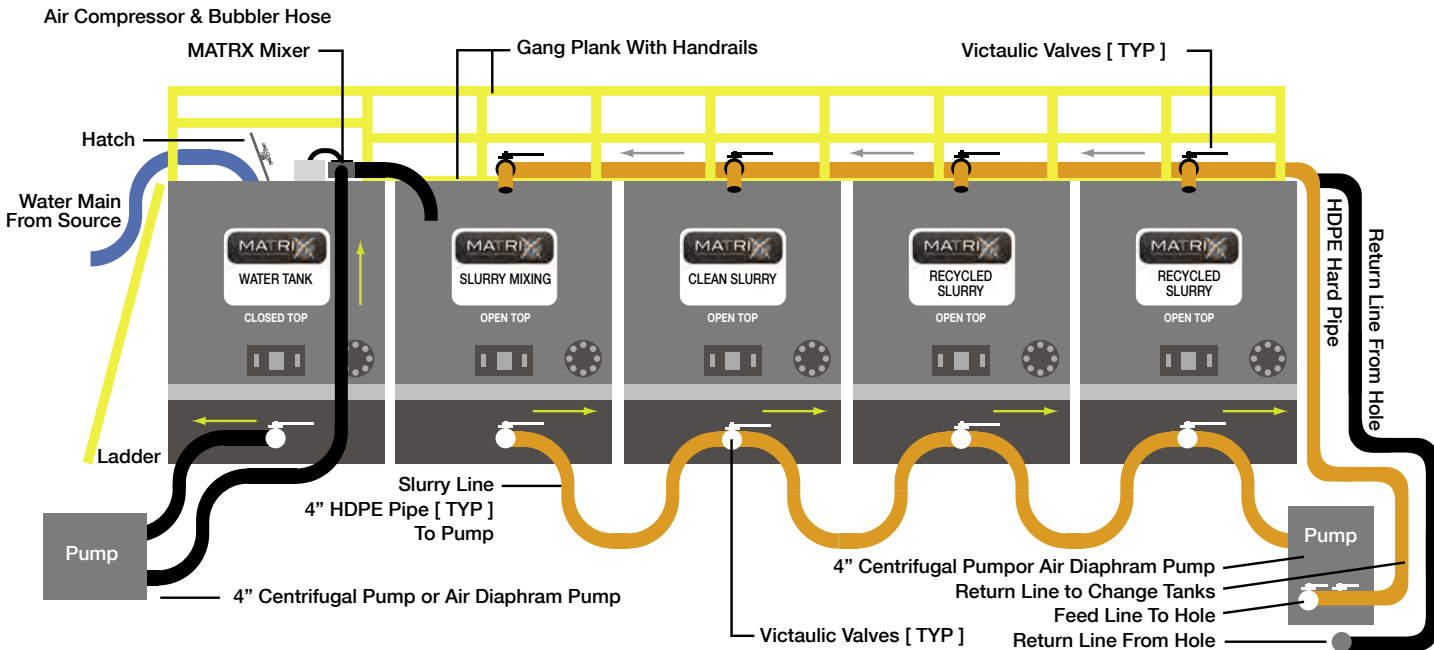

### BIG-FOOT® Polymer Slurry Batch Plant TOP ELEVATION

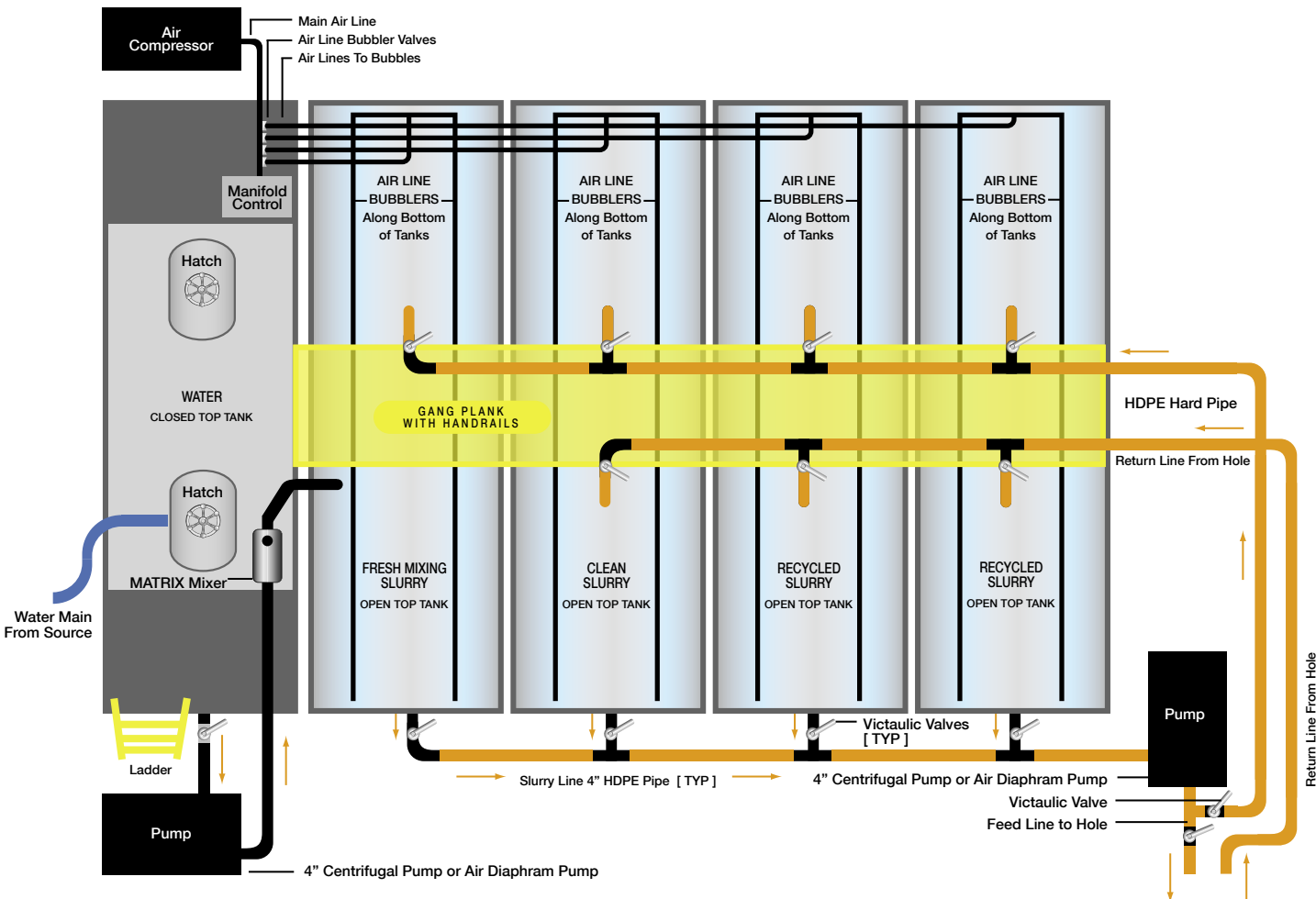





## Mixer on Ground & Tanks







## Tank Set-up On Ground





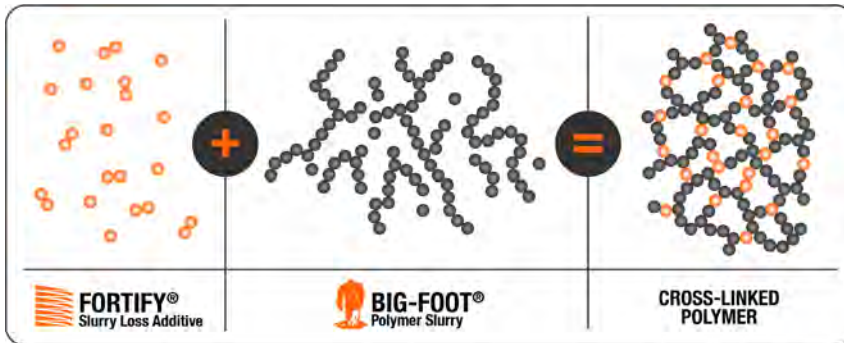

### POLYMER SLURRY MIX WATER SUPPLY

Drilling operations must be provided a consistent water supply of suitable quality for slurry makeup. If the water supply is from an unreliable source, a vessel for water storage should be used to deliver enough uninterrupted slurry making capacity. Unreliable water sources include a small diameter water supply line or a small water tanker truck.

**BIG-FOOT® Polymer Slurry** is a high molecular weight, highly charged anionic, partially hydrolyzed Polyacrylamide (PHPA). The ideal pH for BIG-FOOT slurry in the excavation is 9.0 to 10.0. This pH range will ensure that the BIG-FOOT polymer will fully uncoil and activate to produce the best viscosity. **M-BOOSTER® Dry pH Adjuster** is the safest and most effective way to achieve the pH needed for BIG-FOOT polymer slurry. M-BOOSTER is also recommended to treat out excess calcium (CA++) which negatively effects polymer performance in the mix water. Hardness should be reduced to < 100 ppm. The suggested mix ratio of M-BOOSTER to mix water is typically 5 to 8 lb/1,000 gal (0.6 to 1.0 k/m<sup>3</sup>).

### BIG-FOOT MIXING DOSAGE AND VISCOSITY

BIG-FOOT Polymer Slurry works best when used according to the instructions in the mixing table. The correct BIG-FOOT polymer dosage within the slurry is required to apply the necessary positive differential pressure against the sidewalls of the excavation. The ideal concentration of BIG-FOOT polymer is between 8.0 to 9.0 lb/1,000 gal of mix water (1.0 to 1.1 k/m<sup>3</sup>). At this concentration, the Marsh Funnel viscosity of BIG-FOOT polymer slurry should range between 85-90 sec/qt.

The dosage rate of BIG-FOOT polymer in the original mix should always be added at the higher levels suggested on the dosage chart to start the drilling slurry off with extra viscosity to be prepared for unforeseen subsurface conditions. The mix dosages should only be reduced after the slurry has been used and onsite soil and groundwater conditions proven.



### MIXING PROCEDURE (IN ORDER OF ADDITION):

1. **M-BOOSTER® Dry pH Adjuster** at a concentration of 8 to 9 lb/1,000 gal (1.0 to 1.1 k/m<sup>3</sup>) for a target pH of 9.0 to 10.0.

2. If geology consists of gravels and sand with little or no fines add **FORTIFY® Slurry Loss Additive** at a concentration of 5 to 7 lb/1,000 gal (0.5 to 0.8 k/m<sup>3</sup>) via a MATRIX high shear mixer to promote enhanced rate of hydration and reduce the amount of un-yielded product. ("fish eyes").

3. Add **BIG-FOOT Polymer** through the same mixer at a dosage of 8 to 9 lb/1,000 gal (1.0 to 1.1 k/m<sup>3</sup>) of mix water depending on desired viscosity.

4. Check slurry properties as listed below and record time taken. Check slurry properties when each hole is completed and make required adjustments to bring slurry back into desirable property range.

**Caution: Failure to maintain slurry properties can result in excavation instability.**

5. Once desired slurry properties are reached, the slurry is ready for use.

6. The slurry level should always be higher than the water table or river level in the open-hole section to maintain a constant hydrostatic loading on excavation.

7. Measure Marsh Funnel viscosity. Target viscosity should be in the range of 85-90 sec/qt.



# BIG-FOOT® IN-THE-HOLE Mixing Instructions



Follow this example when **MIXING-IN-THE-HOLE** is necessary.

Follow the **MATRIX CP** order of addition.

**STOP Drilling 3' above known water table.**

Begin to flood hole with water.



**1** Let the hole fill up with 3' of water. Now start adding to the hole. Add **M-BOOSTER® Dry pH Adjuster** into the stream of water as it fills the hole.



**2** Add **FORTIFY® Slurry Loss Additive** (Pre-mix **FORTIFY** as per the following instructions for best results)

EQUIPMENT NEEDED : 1-1/2" portable drill ; Long plaster mixing drill bit

- Take (4) empty 5-gal pails.
- Fill each pail 1/2 water.
- Mix 2 lbs **FORTIFY** into each pail. Mix until a thick slurry is formed.
- Pour all four pails into the hole.



**3** Add **BIG-FOOT® Polymer Slurry**.

**4** Fill-up the shaft. Allow room for the Kelly bar and drill tool so it doesn't overflow.

**5** Stir the slurry using the drill Kelly with tool attached clockwise, then counter clockwise, then up and down.

**6** Begin to drill, keeping the shaft flooded full of slurry as the drilling is advanced down.

### **IMPORTANT PROCEDURE TO FOLLOW:**

**Add more M-BOOSTER + FORTIFY + BIG-FOOT at each 1/3 of the total depth of the shaft.**

BIG-FOOT polymer dosage and slurry viscosity should be selected and controlled within ranges which match the soil and mix water conditions of the individual project. The ranges need to be in accordance with the table below.

	SOIL FORMATION	BIG-FOOT® POLYMER MIX DOSAGE		MARSH FUNNEL VISCOSITY
		lb/1,000 gal	kg/m <sup>3</sup>	sec/qt
	CLAY & SHALE	4.0-5.0	0.5-0.6	40-45
	SILT & FINE-MEDIUM SAND	6.0-6.5	0.7-0.75	75-115
	COARSE SAND-PEA GRAVEL	7.0-8.0	0.8-1.0	120-135
	GRAVEL-COBBLE	9.0-10.0	1.1-1.2	145-175

### MIXING BIG-FOOT POLYMER INTO SLURRY MIX

The prepared slurry fluid should always be pre-treated with **M-BOOSTER® Dry pH Adjuster** as specified by MATRIX Construction Products. It is also recommended to pre-mix the BIG-FOOT polymer in surface mixing systems to improve the yield and performance. Mixing within the excavation increases both the amount of product necessary to reach target values, and the amount of un-yielded, or wasted slurry product.



### PRE-MIXING IN TANKS

When pre-mixing BIG-FOOT polymer in tanks, add the polymer to water that is being passed through a hose or a MATRIX mixing hopper. This avoids the formation of lumps and results in a uniform mixture of polymer in the mix water. Agitation may be accomplished by using motorized stirrers, air injection (blow pipes or fixed perforated piping) or other suitable and effective means. Polymer should be mixed in a tank with sufficient agitation. Recirculation by a single pump, without other means of stirring, is insufficient and should not be allowed unless the mix tank is small enough so that the pump provides adequate circulation of the entire tank. The polymer slurry should be mixed until it develops viscosity adequate to be self-suspending (i.e., particles or partially dissolved polymer do not settle in the fluid). This should occur within 30 to 60 minutes after start of mixing depending on the temperature.

	SLURRY VOLUME TABLE gal/ft			
	DIAMETER FT (IN)	0 IN	3 IN	6 IN
1 (12")	5.88	9.18	13.22	17.99
2 (24")	23.50	29.74	36.72	44.43
3 (36")	52.88	62.05	71.97	82.62
4 (48")	94.00	106.12	118.97	132.55
5 (60")	146.88	161.93	177.72	194.24
6 (72")	211.50	229.49	248.22	267.68
7 (84")	287.88	308.80	330.47	352.87
8 (96")	376.00	399.87	424.47	449.80
9 (108")	475.88	502.68	530.22	558.49
10 (120")	587.50	617.24	647.70	678.93
11 (132")	710.88	743.55	776.97	811.12
12 (140")	846.00	881.62	917.97	955.05

Volume can be calculated with the formula  $(D/2)^2 \div 24.52$  where D is in inches.



## RECYCLED SLURRY UPKEEP MIX DOSAGES

Using maintenance mix dosage guidelines from past project operations, BIG-FOOT polymer should be added into fresh water at the mixing tank and not at the point of existing slurry that is flowing into the next drilled excavation. MATRIX recommends at least one single recycled slurry tank (two preferred for recycled, recaptured slurry based on project size). To improve the strength of the recycled, recaptured slurry, mix BIG-FOOT polymer into fresh water through a MATRIX mixer. The fresh batch of new slurry is then mixed at higher levels from the dosage chart and added to the recycled, recaptured slurry to increase the overall slurry viscosity and pH. We recommend starting the next drilled excavation with the fresh, higher viscosity batch of slurry.

Original slurry dosages will vary depending on site mix water quality, soil porosity and chemical reactivity of the soils being excavated. It is critical to regularly monitor the slurry properties using the Marsh Funnel and Cup, pH Strips and Mud Balance in the excavation. Extra BIG-FOOT dry polymer may be added at the excavation to strengthen existing slurry through a MATRIX mixing system, which will empty directly into the excavation. The excavating tool (auger or bucket) should be plunged and turned gently through the full length of the slurry column while the polymer is being added, distributing the fresh polymer and helping to assure that the polymer mixes into the already mixed slurry.

### The additional benefits of BIG-FOOT polymer at the drilled excavation provide the following:

- Large quantity of polymer gels controls fluid loss
- Rapid increase in viscosity to stabilize highly permeable soils
- Higher reinforcement adhesion within sand and gravels, soils
- **MO'S MUD® Strong Viscosity Booster** added directly into the slurry filled excavation combats each of the above conditions immediately

## MONITORING THE DRILLING SLURRY

Slurry levels should be sustained at least 1.83 m (6 ft) above the water table or at the full level needed to preserve the soil strength and counter balance any hydrostatic soil pore pressure. If slurry levels fall below the specified level, halt drilling action and re-establish proper levels before re-starting process. In certain conditions, MATRIX may instruct that the slurry level be held at less than 6 ft above the water table which will reduce the rate of fluid loss.



When choosing the slurry level please use the water table (piezometric level) as a point of reference for selection and upkeep of the slurry. When casings or other protective sleeves have been placed to a depth at or below the water table it is still necessary to use the water table as a point of reference. If the water level in the ground is at 1-ft below land surface the top casing must be raised to a level 6-ft high above ground. Be sure to allow extra room for the Kelly Bar and drill tool displacement of the polymer slurry. Keep the slurry level up within the casing to prevent sidewall collapse.

Water mixed with the BIG-FOOT polymer slurry weighs 8.40 lb/gal (water weighs 8.34 lb/gal), making it necessary to maintain the slurry level 6' or greater above the surrounding groundwater level. Without this positive pressure exerted by the slurry column against the sidewalls of the drilled excavation, soil overburden pressures can cause the excavation to collapse. In addition, The natural soil overburden pressures forced against the positive pressure exerted by the slurry column can result in little or no leach ability to the surrounding formation.

## SLURRY LOSS

Seepage or direct loss of slurry into the soil is considered “slurry loss”. During high rates of slurry loss, polymer dosage and viscosity of the slurry must be increased as needed to provide satisfactory control within acceptable ranges of slurry viscosity. Slurry loss control agents or treatments that are recommended by the manufacturer can be used instead of, or in addition to this method. All additives used must be certified by the manufacturer as compatible.



To aid in the control and reduction of slurry loss, **FORTIFY® Slurry Loss Additive**, a dry cellulosic polymer, works exceptionally well, especially in sandy soils. FORTIFY added to BIG-FOOT polymer reduces slurry seepage into saturated open sands and gravels and is highly recommended when drilling in loose saturated sands.

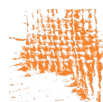

If slurry loss is severe, the additive **GEO-NET® Slurry Loss Material** is recommended. GEO-NET has been designed to be added directly at the drilled excavation. By building a mesh membrane along the sidewalls of the excavation, GEO-NET works where the loss of slurry is occurring.



**MO'S MUD® Strong Viscosity Booster** is an excellent additive. **MO'S MUD** is also very effective as a slurry viscosity booster when added into the excavation, and for the cohesion of sand, gravel and cobbles. MO'S MUD thick gel-like texture combines with fines to assist in plugging up the theft zones and to hold back heaving sands. MO'S MUD may be poured into the top of the hole or can be dropped down in weighted, thin plastic bags that will be shredded and mixed by the drilling tool. MO'S MUD should be mixed with a ratio of 2 gal/2,000 gal of fluid.



## PLANNING FOR POURING CONCRETE

To clean the bottom of the excavation once the final depth in the drilled shaft (Tip) is reached, use either a Clean-Out Bucket or One-Eye. If needed, allow the slurry within the excavation to remain motionless and undisturbed for the amount of time needed to allow sand to settle to the bottom of the excavation. During this static period, slurry tests should be taken periodically from the midpoint and from the bottom of the excavation in order to measure sand content, viscosity, pH and density. Using a design diameter Clean-Out Bucket, clean the bottom of the excavation. When cleaning of the bottom is complete, the rebar cage is inserted and concrete is poured. To help with sand size grains in the fluid not settling quickly, use **RAPID-DROP® Fast Acting Flocculant** and **FAST-FLOC® Rapid Acting Liquid Flocculant** to accelerate cleaning of the slurry within the excavation.

## TIME BETWEEN BOTTOM CLEANING AND PLACEMENT OF CONCRETE

The time between the final cleaning of the excavation's bottom and the pouring of concrete should be no longer than four hours. Project engineers may approve allowances.



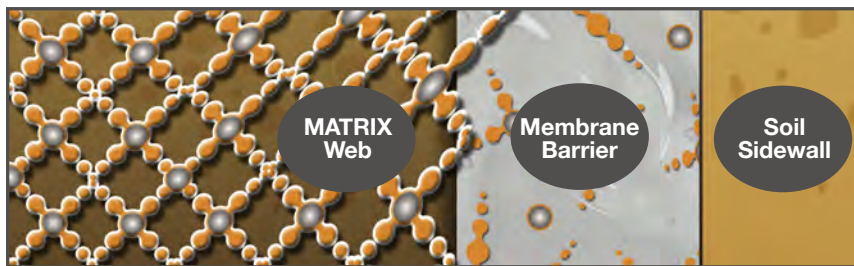

The BIG-FOOT® Polymer Slurry system works by creating a polymeric differential pressure barrier throughout the sidewall of the excavation. The polymer slurry reacts when it comes in contact with freshly exposed soil, creating an organized web of polymer strands. This web allows BIG-FOOT to bond to the sidewall of the excavation.

### DEFINITION AND INGREDIENTS OF BIG-FOOT® POLYMER SLURRY



BIG-FOOT polymer is a nonhazardous, granulated, manufactured anionic polyacrylamide. Made from the co-polymerization of acrylamide and acrylic acid, BIG-FOOT has a very high molecular weight, providing viscosity to low concentrated water.

BIG-FOOT is a synthetic polymer with negative charges on the backbone, and is comprised of a very high molecular weight. Its high molecular weight gives viscosity to low concentrated water. When BIG-FOOT polymer dissolves in an aqueous solution, the long polymer chains also dissolve and then randomly align in the fluid in coils. In fresh water, the abhorrence of the negative charges on the backbone of the polymer chains causes the coils to swell and fill a large volume in the fluid. When the fluid is sheared, the expanded polymer chains are located in various fluid layers of the shear field. Viscosity results when the expanded polymer chains uncoil and the mechanical energy is dissipated.

Due to the extreme length of the high molecular weight polymer chains, different parts of the individual polymer chains may bridge different solid particles. Because of this, the polymer is very effective in preserving solid consolidation while drilling a foundation. Furthermore, it is more difficult for water to be dispersed into the encountered formation due to the adsorbed layer of hydrophilic polymer on rock and soil sidewall surfaces.

### RECYCLING OF BIG-FOOT POLYMER SLURRY

Once slurry testing is completed and the rebar has been positioned, drop a suction line inside the excavation to recycle the slurry. While the concrete is being placed via tremie pipe, the slurry becomes displaced and forced to the top of the excavation. Using a centrifugal pump or Air Diaphragm Pump, pump the BIG-FOOT slurry from the top of the excavation into a holding tank big enough to contain the entire volume of slurry.

Contact with concrete will contaminate the slurry and cause it to resemble oatmeal. Because of this, the last three feet of slurry above the concrete when finished pouring will be contaminated and recycling this slurry back to the tanks should be avoided. The last 4-5 ft of contaminated slurry within the hole should be pumped to a waste tank.

After testing the recycled BIG-FOOT slurry for viscosity, density, pH and hardness add water to restore the original volume and Soda Ash to adjust the pH.



### NEUTRALIZER MIXING INSTRUCTIONS

Take (4) EMPTY 5-gallons buckets. Fill each ½ full of water. Stir in 10-lbs of dry **NEUTRALIZER® Big-Foot Polymer Slurry Breaker** (into ea./bucket) until dissolved. Now pour this (dissolved **NEUTRALIZER** solution) directly into the slurry for a rapid fast breakdown.

**Caution: Be in a well ventilated outdoor area when working with the NEUTRALIZER product.**

Below is the process of breaking down of the MATRIX **BIG-FOOT Polymer Slurry** after it has been Neutralized. After pouring concrete the slurry is pumped back into the frac-tanks onsite. Next, **NEUTRALIZER Big-Foot Polymer Slurry Breaker** is added into the 19,000-gallon tank full of slurry at a dosage rate of 2.5 lbs per 1,000-gallons. The tank full of slurry is then circulated breaking the entire volume back to water at a viscosity close to 30-sec/qt .

### BREAKDOWN OF BIG-FOOT SLURRY

**BIG-FOOT® Polymer Slurry** fluids are classified as “relatively harmless” and are readily degradable through chemical or physical means upon completion of a slurry job. Once the project is complete, the remaining **BIG-FOOT®** polymer is broken down according to local rules and regulation with the chemical oxidizer **NEUTRALIZER**. This is added to the slurry to be treated. After the **NEUTRALIZER** is added, the slurry is continually recirculated for approximately 3 hours. using the pumps on-site to ensure complete oxidation of the polymer molecules. At that point a viscosity test is performed to see if more recirculation is needed to achieve a 30-sec./qt. time.



**877.591.3137 P 906.542.4387**  
**orders@matrixcp.com**





**BIG-FOOT<sup>®</sup>**  
POLYMER SLURRY

Clay and Silt Stabilization      Improves Borehole Stability  
 Minimizes Spoils                      Non-Gelling / Self-Cleaning

Product	Net Weight (kg)	Net Volume (L)	Net Volume (US Gal)
Big-Foot 1000	1000	1000	26.4
Big-Foot 2000	2000	2000	52.8
Big-Foot 3000	3000	3000	79.2
Big-Foot 4000	4000	4000	105.6
Big-Foot 5000	5000	5000	132.0
Big-Foot 6000	6000	6000	158.4
Big-Foot 7000	7000	7000	184.8
Big-Foot 8000	8000	8000	211.2
Big-Foot 9000	9000	9000	237.6
Big-Foot 10000	10000	10000	264.0

**MATRIX**      Net Contents: 25.0 (11.8) US Gal

**NSF**







877.591.3137 P 906.542.4387

orders@matrixcp.com Colorado • Michigan

© 2021 MATRIX Construction Products LLC

Printed on Recycled Paper

ver2021-05

